



Ultrasonic Meter Type BTU METER , DISTRICT

uFlow 230 SERIES

DN125 - 1000



1. Introduction

The **uFlow 230** series ultrasonic BTU meter can be used for measuring the energy consumption in heat / cooling application for billing purpose. The measurement principle is static and based on the measurement of transit time with pair of ultrasonic transducer propagating at each other upstream and downstream. All calculation and flow measurement circuits are designed on one circuit board, thus offering exceptional accuracy and reality.

2. Features

- High capacity 3.6 lithium battery inside, above 8 till 10 years shelf life.
- Dynamic range of 250:1, 100:1, 50:1
- Can be mounted in flow pipe or return pipe, and can be mounted horizontally or vertically.
- Support optical, RS485 and wired & wireless M-bus interface, convenient for user to manage data in different manners.
- Complies to Modbus RTU and EN13757 communication protocol.
- Certified by CMC and MID.
- Advanced calibrating device, adopt international advanced automatic heat meter calibration device, ensure the product accuracy.
- Can be used as cooling, heat or combined climatic meter.

3. Application

- Green building management
- Tenant billing
- Energy management

4. Dimensions

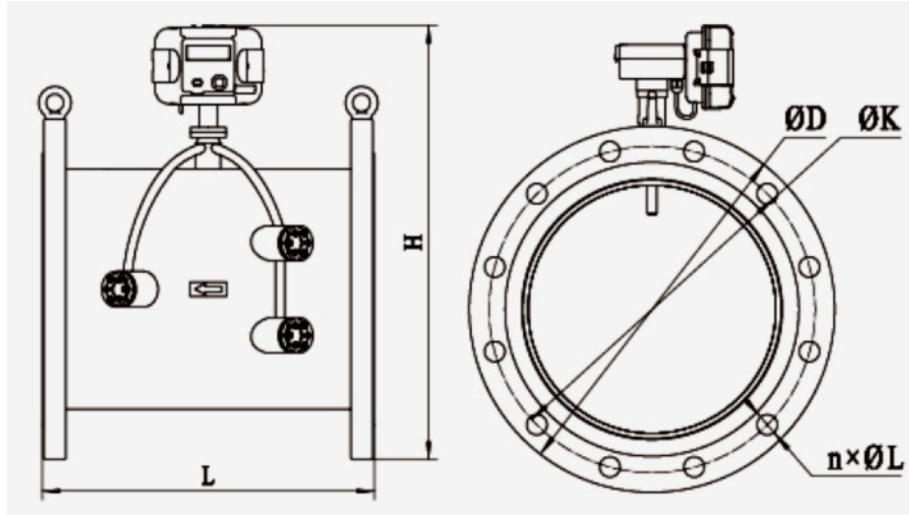

Nominal Diameter (mm)	125	150	200	250	300	350	400	450	500	600	700	800	900	1000	
Nominal flow rate : qp (m³/h)	17	20	30	45	75	100	130	150	190	350	500	600	750	950	
Dimension (mm)	L	350	350	350	400	450	500	550	600	650	750	875	1000	1230	1300
	D	250	285	340	405	460	520	580	640	715	840	910	1025	1125	1255
	H	388	418	476	535	589	645	699	756	819	931	1081	1166	1266	1381
	K	210	240	295	355	410	470	525	585	650	770	840	960	1050	1170
	N x ØL	8 x Ø18	8 x Ø22		8 x Ø26			8 x Ø30		8 x Ø33	8 x Ø36		8 x Ø39		8 x Ø42
Weight (kg)	17	20	30	45	75	100	130	150	190	350	500	600	750	950	
Channel	Single, double, three or four channels optional										Double, three or four channels optional				
Pressure Loss (kPa/qp)	7	6	4	4	4	2	2	2	2	2	2	2	2	2	
Working Pressure	1.6MPa (2.5MPa can be customized upon request)														

5. Technical Specification

SPECIFICATIONS - Calculator	
Display	LCD, 8 digits Energy, power, volume, temperature, flow rate
	Cummulative heat energy: KWh or MJ (display range: 0~9999999.9), Thermal power: KW
	Instantaneous flow: m ³ /h, cumulative volume:m ³ , Supply water temperature: °C. Return water temperature: °C, Temperature difference, Total operating time
Approval	MID
Language	English
Ambient Storage Temperature	A Class (5~55) °C or B Class (-25~55)°C optional
Temperature Measuring Range	4-95°C, 130°C can be customized
Temperature Sensor	PT1000 (PT500, PT100 can be customized)
Cable length of temperature sensor	1.3 meters
Power supply	3.6V lithium battery
Battery lifetime	≥10 years
Installation	Horizontal or vertical
Communication	Modbus, M-bus, optical, pulse
IP rating	IP67
Accuracy	Class 2
Mounting Position	Vertical or horizontal

TECHNICAL PARAMETER	
Flow velocity	0.1 ~ 7m/s
	0.15~12m/s (need to be customized)
Maximum Volume	999999.99
Maximum Heat	999999999

6. Order Information

Model Number, Example and Option								Description
U-230	- H -	DN125	- I	- 1	- D	- D	- N	
Meter Type	H							Heat
	CH							Cooling / Heat
Meter Size	DNXX							Please specify size (DN125 -1000)
Installation Situation		I						Inlet
		O						Outlet
Output Interface Option			0					M-Bus
			1					RS485 / Modbus *
			2					Pulse *
			3					BACnet *
			4					GSM wireless **
			5					RF wireless **
			6					Others please specify
Power Supply			D					24VDC
			A					95-265VAC
			1					Battery Supply ***
Flange Connection			D					DIN (EN13757)
			A					ANSI
Temperature Range				N				4 ~95 °C (Default)
				H				
Extra Requirement								(Eg. Cable length, probe type)

- * External power required for communication
- ** Converter would be used to provide required communication
- *** For display monitoring

Example:

U-230-H-DN125-I-1-D-D-N calls for flange type DN125 BTU meter; RS485 Modbus interface; 24V DC External Supply; DIN standard; Temperature range: 4~95°C

Cable length:

- Flow sensor cable (Default: 0.6 meter)
- Temperature probe cable (Default: 1.3 meter)

Pressure rating:

- 1.6MPa (Default)
- 2.5MPa (Customized)

Temperature probe type:

- PT1000 (Default)
- PT500



Address:
40 E Main Street,
Newark DE, 19711 USA



Phone:
(302) 246 1338
Fax:
(302) 246 1339



Email:
sales@ppkinetics.com